

EASYCRANE™

Flexible articulated jib crane with integrated vacuum lifter

Easycrane is a complete stand-alone lifting solution for fast and easy lifting. With a generous range and a height-adjustable floor pillar, it is adaptable to most workplaces. Add a mobile footplate and you can easily move Easycrane with a simple manual pallet truck between different workstations.



EASYCRANE gives you many advantages!

- Quick and easy lifting of loads up to 45 kg
- With a mobile footplate, no installation is required
- Loads can be grabbed horizontally and vertically and rotated freely
- A large selection of different suction cups and vacuum yokes
- Quick connection for easy replacement of suction cup or tool

Common LIFTING APPLICATIONS:

Cardboard boxes, sacks, panels, barrels, furniture, and more ...

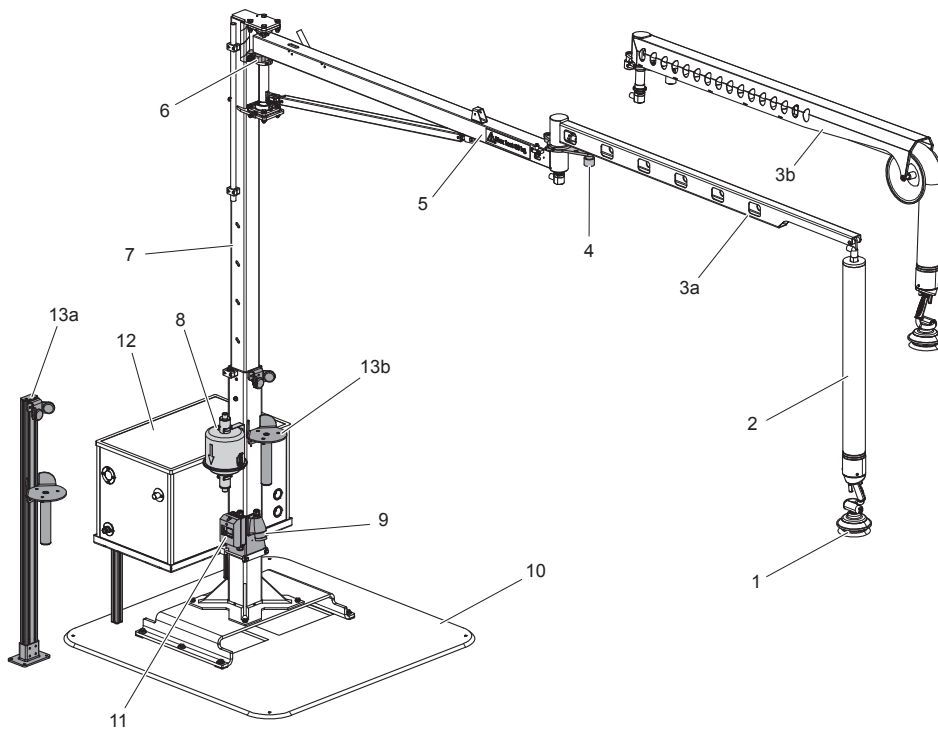

General data

Max. load jib crane	[kg]	50
Max. load vacuum lifter	[kg]	5-45
Jib arm reach	[mm]	2000 - 4000

- 1. Suction cup
- 2. Lifting hose
- 3. Outer jib
- 4. Rotation limiter
- 5. Inner jib
- 6. Inner brake
- 7. Adjustable tower
- 8. Filter
- 9. Electric connection (400V, 16A)
- 10. Mobile footplate
- 11. Power switch
- 12. Vacuum pump
- 13a. Parking suction cup, version a
- 13b. Parking suction cup, version b



LIFTING WITH EASYCRANE

Easycrane is a complete lifting unit designed for lifting loads up to 45 kg. The crane is equipped with a vacuum lifter that is connected to a vacuum pump, located on a shelf beside the crane.

Easycrane is extremely versatile and can be used to handle loads of different size, shape and weight. The load can be gripped both horizontally and vertically, and rotates freely.

Easycrane is intuitive and easy to use, and in many cases increases operating speed and productivity, while protecting the user from strain injuries.

The crane's tower is adjustable in height and can either be mounted on a mobile footplate or attached directly to the floor with expander bolts.

Easycrane has an inner and an outer jib arm that both can be locked in rotation. Both inner and outer jibs are available in three different lengths and the outer jib can also be obtained in two different designs. One version with a lifting hose with fixed length and one for workplaces with low ceilings where the lifting hose runs over a wheel.

On the inner jib there is a parking brake that can be used to prevent the arm from "walking" from position. Between the inner and outer jibs are two rotational limiters restricting the rotation angle of the outer jib.

Several different variants of suction cups and vacuum yokes are available. As an option, there is also a parking position to hang the vacuum suction cup when the lift is still in operation.