

IE-Industrial ECO



Lift&Drive

90IE-Industrial ECO

 PRONOMIC

Lift&Drive - Industrial ECO

Our Swedish-made lift trolley, adapted to meet the demanding requirements of the industrial environment

The IE-model is a light weight ergonomic and very practical lift trolley. Adapted for use in industry, practical even for applications, warehouses, post offices, catering services etc. Perfect for many different applications within the industry. With this type of trolley you increase the productivity and at the same time you create a better and safer working environment for the user.

Available with a lifting capacity of 90 kg. The IE is available in powder coated or stainless steel. The lift trolley is strong and lightweight due to it's aluminium construction. The handles and remote are height adjustable to best suit the operator. The remote is also removable from the handle, for precision handling.



Security and features

- To ensure maximal safety the trolley possess a built-in release function, which serves as protection from crushing injuries and prevents the trolley from tipping over.
- Height-adjustable handlebar, easy to use hand control.
- Industrial wheels for durability.
- Spindle drive with safety clutch.
- Ergonomically curved handles to offer extra support.
- Several of lifting attachments
- Columns are available in three standard heights, others heights on request
- Maintenance free batteries
- Inbuilt overload protection
- Highly manoeuvrable and lightweight
- Powered by 24V battery

We manufacture forks in your desired dimensions, no extra charge

Forks to the required measure

Choose rectangular, round or flat iron tubes and a length and a width, between 50mm and 500mm. And we manufacture a fork that is tailored to your needs.

Special adapted - to a standard price.

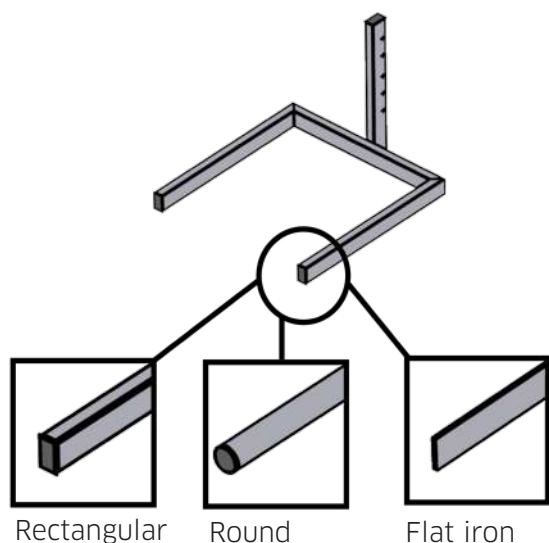

Accessories

Apart from the standard platform, there are a number of other standard accessories available.



Standard platform.
For cartons , boxes, crates, etc.
560x440mm
Article.no. 15338+15322



Top plate in stainless steel(442x498mm)
Can be placed on top of the plastic platform.
Article.no.15018



Expand&Turn Light.
Designed to handle 3" (76mm) reels in the core.
Article.no.17940



Edge Roller.
Length 300 mm
Article.no. 15026A



V Block and turntable.
Perfect for reel handling.
Rotatable 360°
Article.no.17229 + 17233



Prong for roll handling.
Tool for lifting rolls in the core.
Length 500mm
Ø60.3mm
Article.no.17241

Technical Specifications

Technical Specifications for Lift&Drive 90IE

	Overall height, standard	Length of stroke	Lifting height (least)	Lifting height (max)
Mast standard	1682	1192	127	1319
+250	1932	1442	127	1569
+500	2182	1692	127	1819
Total width		555 mm		
Length		771 mm		
Loadplatform (LxB)		560x440 mm		
Wheel diameter (front/rear)		60/82 mm		
Maximum load		90 kg		
Dead weight		40 kg		
Lifting speed (mm/s)		98/85		
Battery voltage		24 V		
Batteri capacity		7,2 Ah		
Charging voltage		230VAC/50Hz or 115VAC/60Hz		

Material, Lift&Drive 90IE Chassis in powder-coated steel

Material, Lift&Drive 90IES Chassis in stainless steel

The platform can if necessary be moved up 110 mm in the slide, to increase lifting height.

Our products are designed in accordance with the standards and are CE-marked.

For further info
please contact your
sales representative

”
Your leading
specialist for
ergonomic lifting
tools

”